

MO-3



u s e r ' s g u i d e

**AMERICAN
TECHNOLOGIES
NETWORK
CORP.**



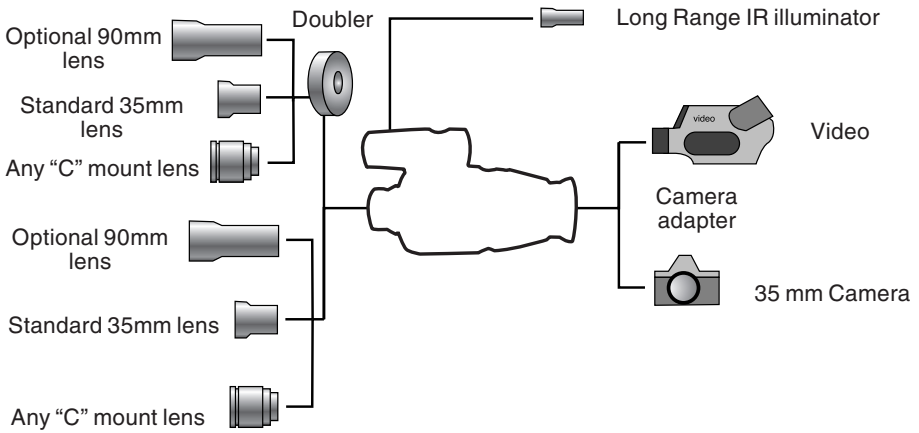
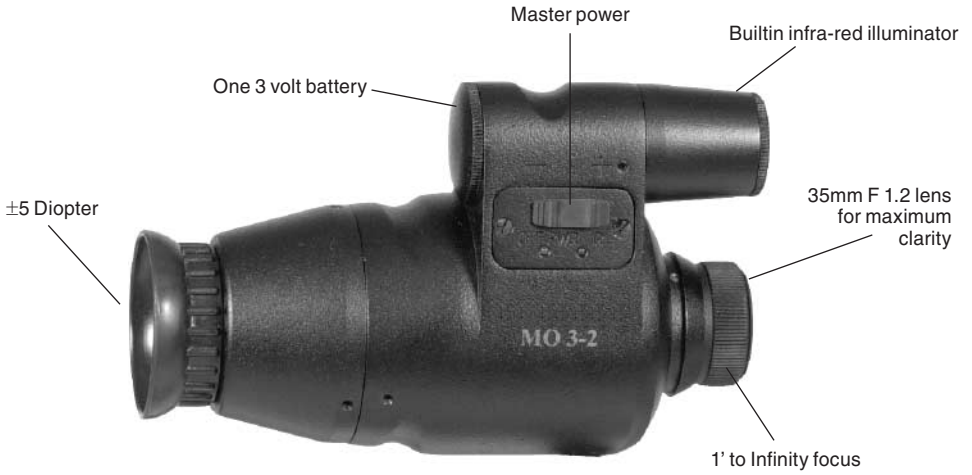

Camera adapter



Optional focal length doubler gives the NightStar increased magnification, in just seconds, without any tools.

The information in this manual furnished for information use only, is subject to change without notice, is not to be construed as a commitment by ATN Corp.

ATN Corp. assumes no responsibility or liability for any errors or inaccuracies that may appear in this book.

©2001 ATN Corp. All right reserved.

APPLICATION

The MO3-2 Night Vision Monocular is a complex optoelectronic system for individual use. The device consists of (see above figure) the objective lens assembly, eyepiece and the body. The body contains a 2nd Gen. D-grade image intensifier tube assembly with an integrated high voltage power source and the three volt battery housing. D-grade tubes are tubes that did not pass our tube certification test typically do too many cosmetic imperfections on the tube. These imperfections are normally seen as black spots in the viewing area. These blemishes do not affect the light gain, or lifespan of the tube.

The MO3-2 is equipped with a built-in infra-red illuminator for total darkness viewing. Plus, with numerous accessories available (90mm lens and doubler for 4x and 8x magnification, Universal camera and camcorder adapter, Long Range and IR-450 infra red illuminators) the MO3-2D is one of the most versatile least expensive 2nd generation units on the market.

Objective lens protective cover (not shown) is intended to protect the objective lens from dust and scratches. It also will act as a daylight filter, allowing you to test the scope in daylight or other bright light situations. The pinhole in the center of the protective cover allows the user to check the operation ability of the device in daylight conditions.

NOTE: Do not test the scope in daylight conditions even with the daylight filter/lens cap on for more than ten (10) minutes.

The device is powered up by sliding the switch on the side of the unit labeled "PWR".

FEATURES

- Great for hunting, camping, boating or surveillance
- Total darkness technology
- Automatic brightness control
- Built-in IR illuminator
- Manual focus
- Adjustable eyepiece
- High res. 2nd Gen. D-grade image intensifier tube
- Rugged and versatile design
- Light weight and comfortable
- Water and dust resistant
- Single switch button operation
- Superb 1X lens system
- Optional Doubler & Lens allows 2X to 8X magnification
- Soft case
- Two years warranty (optional extended warranty)

SPECIFICATIONS

Magnification	1X (Optional 2X, 4X, 8X)
Intensifier tube	High res. 2nd Gen. D-grade
Lens System.....	35 mm; F1.4
Field of view.....	20°
Resolution	40lp/mm
Range of Focus.....	1' to ?
Power Supply.....	3 volt lithium
Battery Life	10-20 hours
Operating Temp.	-30°F to +110°F
Dimensions.....	140 X 85 X 60 mm (5.5" X 3.5" X 2.5"
Weight.....	0.4 kg (9.5 oz)

OPERATION

- Take the monocular out of the case.
- Install the battery into the housing with the polarity order as shown on the scope. Battery Type: 3 Volt Lithium, #CR123A .When installing the battery one should keep in mind that the polarity of the battery should coincide with the diagram on the body next to the battery housing cap.
- Slide the switch to turn the unit on with the protective lens cover still attached to the lens. **Do not turn the unit on in the daytime without the protective lens cap on.** You should see green glow in the eyepiece.
- Observe the scene and adjust the diopter for optimal image clarity.
- You may now enter a dark environment or simply shut the lights off in order to darken the room.
- Next, remove the lens cap/daylight filter. Adjust the front lens for the distance of the focus. You should not have to readjust the diopter.

FOCUSING



To focus the NightStar, first you will need to adjust the diopter. Simply turn the diopter clockwise until it stops. Then, while looking through the diopter at an object, slowly turn the diopter back counter clockwise until the grain in the image is sharp.

NOTE: We suggest that you focus the diopter during daylight with the filter on.

Next focus the front lens until the image and the grain are both sharp. When you are in low-light conditions and the daylight filter is off, you may focus the front lens to receive sharp image, the diopter should not be adjusted.

NOTE: The front lens should be readjusted as you view objects at different distances.

INFRA-RED ILLUMINATOR



Infra-red illuminators, or IR illuminators, are common to night vision. The IR light greatly enhances the performance of the NightStar while remaining almost totally invisible to the naked eye. The IR illuminator on the NightStar is located underneath the front lens, next to the battery compartment.

The IR illuminator is powered up by sliding the switch to position labeled "IR". It is important to remember that the IR illuminator is simply an infra red light source, and like any light source, it may lose its effectiveness over a great distance.

STORAGE AND CARE

- If the device is not to be used for extended period of time (more than 10 days) remove the battery.
- Avoid touching lenses. If fingerprints or traces of dirt or dust appear, clean their surface with a Photographic lens cleaning tissue.
- Keep lens cap/daylight filter on when not in use.
- The MO-3 is not harmful to the user or the environment.
- Do not disassemble except to clean the front lens and eyepiece: **it will void your warranty.**

- Evaluate the monocular function by looking through it in a lit environment **with the daylight filter lens cap on**. **Never use in daylight without the daylight filter lens cap on**.
- **Never point the MO-3 at a bright light source.**
- Adverse atmospheric conditions such as fog, smog, or haze and a lack of ambient light (moon or starlight) may diminish the effective viewing distance.

USING THE 3X TO 8X DOUBLER *(optional)*

Unscrew 35 mm lens off the body of the MO-3 (make sure that the unit is turned off). Screw the doubler into the body of the MO-3 where the 35 mm lens was removed. Screw the 35 mm lens or your 90 mm lens into the doubler.

NOTE: You can also add just the 90mm lens to a MO-3 without a doubler.

NOTE: When attaching the doubler do not be afraid to use a little force.

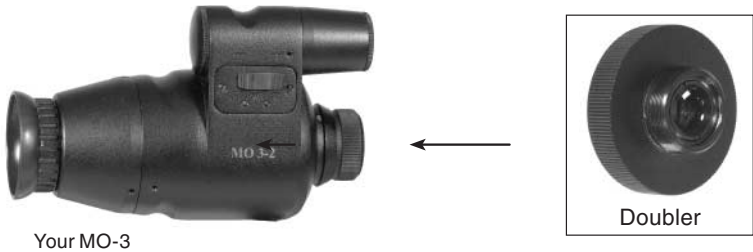

USING THE CAMERA ADAPTER *(optional)*

To use your MO-3 with a 35mm camera or camcorder you will need the following:

- 1) If you plan to use a camcorder, then your camcorder must have a MACRO feature. Most modern camcorders today have a MACRO feature built-in.
- 2) If you plan to use a 35mm camera, you will need a MACRO lens. If you don't have one, we advise that you contact your local camera store.
- 3) You may or may not need a STEP-UP or STEP-DOWN ring in order to adapt the camera adapter to your lens.

NOTE: The camera adapter comes with 37mm and 52mm threads. If you need other sizes your local camera store should be able to help.

- Remove the rubber eyecup from the MO-3



- Screw the camera adapter onto the front of the lens on your Video camera's lens or your 35mm camera's lens.
- Loosen the three set screws on the camera adapter.
- Place the camera adapter over the MO-3's eyepiece.
- Tighten the three set screws to fit snugly to the MO-3's eyepiece
- You may need to focus the 35mm camera or video camera in combination with the MO-3 in order to get the sharpest possible image.
- We suggest that you find an open space to work in. Focus the MO-3 so that the scene is at its sharpest. For best results you should disable the auto focus (if any) on either the 35mm camera or the video camera and manually focus the 35mm camera or the video camera. Once the image is sharp, then simply adjust the MO-3's front lens to change the focus.
- An important part to remember is that you are not taking a picture of an object that is far away from you, but you are actually taking a picture of the phosphorous screen of the MO-3 that is only 2-3 inches away.

CLEANING THE EYEPIECE

You may need to clean the eyepiece of the MO-3 from time to time in order to guarantee top performance. When you receive your MO-3 you should check for dust on the eyepiece of the unit.

First you will need to remove the eyepiece. To do that you will need to initially loosen the 2 set screws that can be found on the base. Then unscrew the eyepiece counter-clockwise to remove it.

NOTE: *You do not have to remove the set screws completely, they are very small and easy to misplace.*

CAUTION: *Use only Photographic lens cleaning tissue on these surfaces. Be careful not to scratch or smudge any of these surfaces. When using compressed air to blow dust away, make sure to avoid inverting the can while spraying. This can cause frozen propellant to exit the can, which can cause serious problems with the glass and phosphor screen.*

TROUBLE SHOOTING:

Q: Flashes, flickers, or clicking occur while operating

S: If it occurs within the first five minutes of inserting new batteries, it is normal and the device will resume normal operation soon thereafter. If it occurs for more than 10 minutes, contact for service instructions.

Q: Dark spots on screen.

S: These are either cosmetic blemishes in the intensifier tube or dust particles.

Q: Screen becomes darker than at previous use.

S: Replace batteries. If problem persists, contact your dealer or other authorized service representative for service instructions.

Q: Image not clear.

S: Adjust objective lens, and/or the eyepiece.

2 YEAR PRODUCT WARRANTY

This product is guaranteed to be free from manufacturing defects in material and workmanship under normal use for a period of 2 (two) years from the date of purchase. In the event a defect that is covered by the foregoing warranty occurs during the applicable period stated above, ATN, at its option, will either repair or replace the product, and such action on the part of ATN shall be the full extent of ATN's liability, and the Customer's sole and exclusive remedy. This warranty does not cover a product (a) used in other than its normal and customary manner; (b) subjected to misuse; (c) subjected to alterations, modifications or repairs by the Customer or by any party other than ATN without prior written consent of ATN; (d) special order or "close-out" merchandise or merchandise sold "as-is" by either ATN or the ATN dealer; or (e) merchandise that has been discontinued by the manufacturer and either parts or replacement units are not available due to reasons beyond the control of ATN. ATN shall not be responsible for any defects or damage that in ATN's opinion is a result from the mishandling, abuse, misuse, improper storage or improper operation, including use in conjunction with equipment which is electrically or mechanically incompatible with or of inferior quality to the product, as well as failure to maintain the environmental conditions specified by the manufacturer. **CUSTOMER IS HEREBY NOTIFIED THAT OPERATION OF THE EQUIPMENT DURING DAYLIGHT HOURS OR UNDER ANY EXCESSIVE LIGHT CONDITIONS MAY PERMANENTLY DAMAGE THE INTERNAL COMPONENTS OF THE UNIT AND SAID DAMAGE WILL NOT BE COVERED UNDER THIS WARRANTY.** This warranty is extended only to the original purchaser. Any breach of this warranty shall be waived unless the customer notifies ATN at the address noted below within the applicable warranty period.

The customer understands and agrees that except for the foregoing warranty, no other warranties written or oral, statutory, expressed or implied, including any implied warranty of merchantability or fitness for a particular purpose, shall apply to the product. All such implied warranties are hereby and expressly disclaimed.

LIMITATION OF LIABILITY

ATN will not be liable for any claims, actions, suits, proceedings, costs, expenses, damages or liabilities arising out of the use of this product. Operation and use of the product are the sole responsibility of the Customer. ATN's sole undertaking is limited to providing the products and services outlined herein in accordance with the terms and conditions of this Agreement. The provision of products sold and services performed by ATN to the Customer shall not be interpreted, construed, or regarded, either expressly or implied, as being for the benefit of or creating any obligation toward any third party of legal entity outside ATN and the Customer; ATN's obligations under this Agreement extend solely to the Customer. **ATN's liability hereunder for damages, regardless of the form or action, shall not exceed the fees or other charges paid to ATN by the customer or customer's dealer. ATN shall not, in any event, be liable for special, indirect, incidental, or consequential damages, including, but not limited to, lost income, lost revenue, or lost profit, whether such damages were foreseeable or not at the time of purchase, and whether or not such damages arise out of a breach of warranty, a breach of agreement, negligence, strict liability or any other theory of liability.**

PRODUCT WARRANTY REGISTRATION

In order to validate the warranty on your product, ATN must receive a completed Product Warranty Registration Card for each unit. Please complete the form below and immediately mail it to our Service Center: ATN Corporation, 20 South Linden Ave., Suite 1B, South San Francisco CA 94080. Products qualifying for warranty repair will be either repaired or replaced within 10 business days of receipt of merchandise unless the customer is notified otherwise.

OBTAINING WARRANTY SERVICE

To obtain warranty service on your unit, take or send the product, postage paid, with a copy of your sales receipt to our service center, ATN Corporation at the address noted above. All merchandise must be fully insured with the correct postage; ATN will not be responsible for improper postage, or, missing or damaged merchandise during shipment.



For customer service and technical support, please contact
American Technologies Network Corp.

North American Office

20 S. Linden Ave. Suite 1B, South San Francisco, CA 94080
phone: 800-910-2862, 650-875-0130; fax: 650-875-0129

European Office

phone: 44(0)870-0111286, fax: 44(0) 845-3349142

The following countries can use our
toll free number 00 800 9102-8620

Austria, France, Germany, Holland, Italy, Spain, Sweden, Switzerland

www.atncorp.com