

ATN OU-R3X

REFLEX SIGHT/3X SCOPE

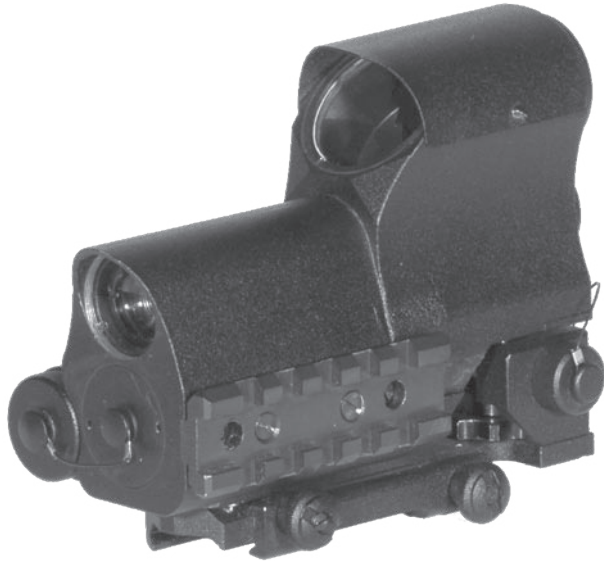

u s e r ' s g u i d e

Important Export Restrictions! Commodities, products, technologies and services contained in this manual are subject to one or more of the export control laws and regulations of the U.S. Government and they fall under the control jurisdiction of either the US Department of State or the US BIS-Department of Commerce. It is unlawful and strictly prohibited to export, or attempt to export or otherwise transfer or sell any hardware or technical data or furnish any service to any foreign person, whether abroad or in the United States, for which a license or written approval of the U.S. Government is required, without first obtaining the required license or written approval from the Department of the U.S. Government having jurisdiction. Diversion contrary to U.S. law is prohibited.



**AMERICAN
TECHNOLOGIES
NETWORK
CORP.**

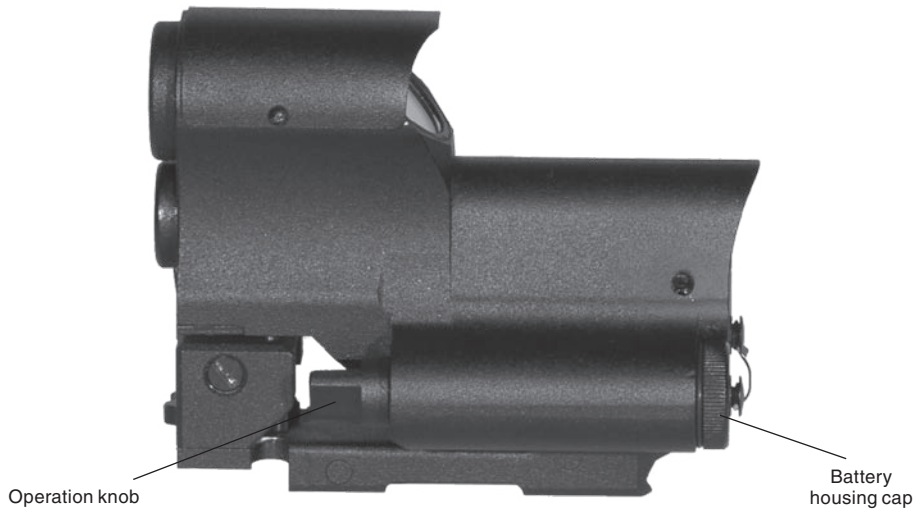
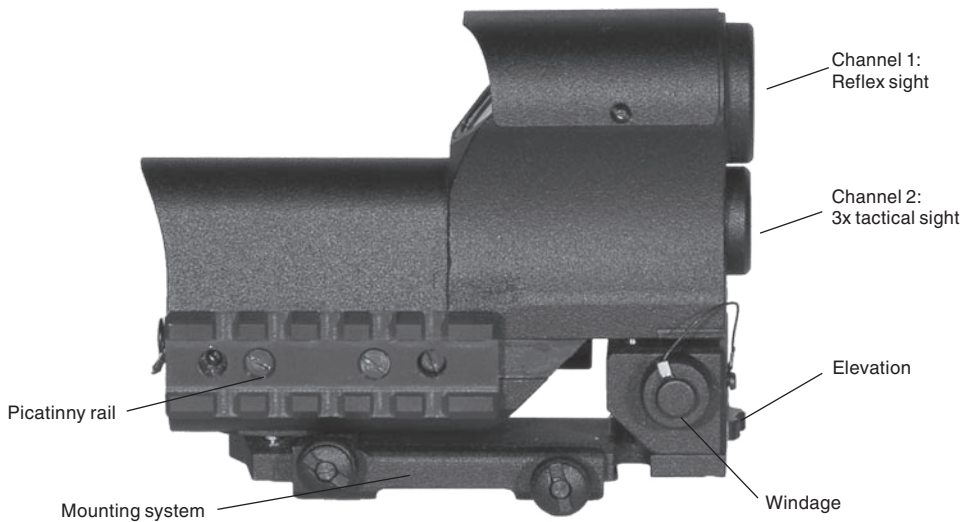

The information in this manual furnished for information use only, is subject to change without notice, is not to be construed as a commitment by ATN Corp.

ATN Corp. assumes no responsibility or liability for any errors or inaccuracies that may appear in this book.

©2008 ATN Corp. All right reserved.

FEATURES

- A true innovation
- Unique dual channel device
- Channel 1: Reflex sight
- Channel 2: 3x tactical sight
- 3X magnification, F:1.4, f26mm lens (Channel 2)
- Multi coated Optics
- Prosheild and Everlight Lens coatings
- Easy to mount, equipped to fit Weaver bases picatinny rail
- Limited lifetime warranty.
- Dimensions: 126 x93x60 mm
- Weight: 350 g.

* ATN reserves the right to change the above specifications at any time without notice

APPLICATION

Everything and anything except the ordinary. The new OU-R3X is a revolutionary breakthrough. This dual channel device combines a red dot reflex sight with a highly accurate 3x device. The reflex sight is perfect for the close quarter combat scenario with the 3x sight available for those longer shots. The OU-R3x is an advanced and extremely universal sight.

OPERATING

MOUNTING

1. Slightly loosen the fixing screws on the weaver rail built into the device.
2. Place the device on the rail of the firearm making certain that the mount aligns with the receptor attachment screw groove. Adjust as necessary.
3. Tighten the fixing screws.

NOTE: Receptor attachment screws may need to be tightened after continuous shooting.

BATTERY INSTALLATION

Install the battery into the housing with the polarity order as shown on the device. Battery Type: 3 Volt Lithium battery type CR132A.

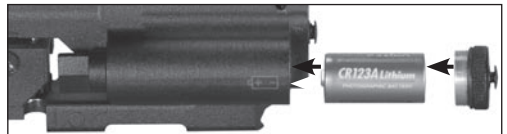

WINDAGE AND ELEVATION

The vertical and horizontal adjustments for the OU-R3X can be achieved by turning the elevation and windage adjustment mechanisms (remove dust cap first). Each click equals to 1/4 inches at 100 yards. When reaching the maximum of rotation do not use force.

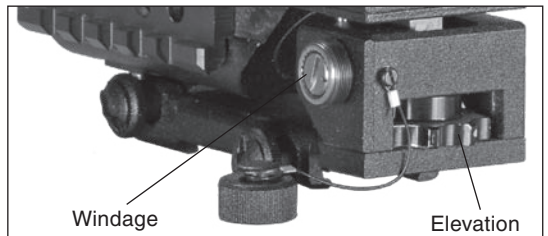

OPERATING

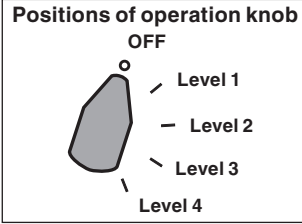
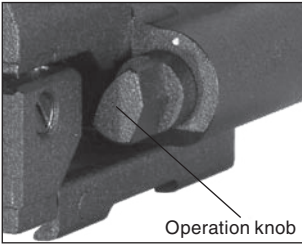

The OU-R3U has a one knob operation control. The operation knob has an OFF position marked white dot and 4 positions of different brightness levels. Positions of operation knob is shown on figure. The Level 1 position corresponds to minimal level of reticle brightness. The Level 4 corresponds to maximal level of reticle brightness.

To turn on the upper reflex sight channel and illumination of reticle of lower channel rotate operation knob from OFF position.

When the device is not used rotate operation knob to OFF position.

ELECTRONIC RETICLE

Upper channel reticle

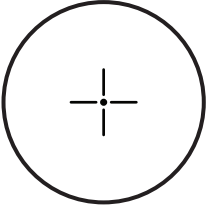

Your device has an electronic reticles. The brightness of reticle illumination changes in both channels simultaneously.

Upper channel

The upper channel of OU-R3X has a Cross Hair with Dot reticle with four positions of illumination.

Hold the device away from you and look through it with both eyes open to see a reticle pattern of reflex sight channel.

Lower channel

The lower channel of OU-R3X has a Plex reticle with four positions of illumination.

Lower channel reticle

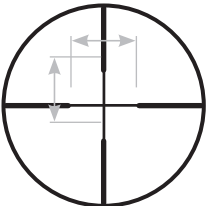

The reticle gives a clearly aiming point, even when hard-to-see game blends into the background. Posts and crosshairs center section covers a minimum of the target and allow for less target coverage, making precision shots on small target easy.

The size of thin cross-line in the middle of reticle correspond to 2 yards at 100 yards distance.

ZEROING

Pre-zeroing is recommended and can be done in accordance with a device guide or owner's instructions.

CAUTION: *Be sure gun is not loaded. Always use safe gun handling procedures.*

All shooting should be done at an approved range or other safe area. Eye and ear protection is recommended.

DANGER: *If you used a bore-obstructing device, remove it before proceeding. If the barrel has-been drilled for a mount, check that the screws do not protrude into the bore. Do not fire live or even blank ammunition with an obstructed barrel. An obstruction can cause serious damage to the gun and possible injury to you and others nearby.*

From a steady position, fire three rounds at a target. Observe the impact errors and estimate the correction value. Adjust windage and elevation handles as needed to correct aim.

Remove the dust caps from the top of the windage and elevation adjusting handles.

Turn the windage and elevation handles through the number of clicks necessary for an amendment.

NOTE: *Each click of adjustment changes bullet strike by the amount shown on the chart below.*

Windage/Elevation (inches of movement per click)

100 Yards - 1/4"
200 Yards - 1/2"
300 Yards - 3/4"
400 Yards - 1"
500 Yards - 1 1/4"

When you have finished adjustment of fire, recap windage mechanisms.

MAINTAINING YOUR DEVICE

Your device is weather resist and shock-proof. However, you should never try to take apart or clean it internally (it will void your warranty). If your scope ever does need repairs or adjustments, it should be returned to ATN's service department. The exposed optical surfaces will perform their best if they are occasionally wiped clean with a lens cloth or with optical quality lens paper like those for eyeglasses

or camera lenses. Maintain the metal surfaces of your rifle scope by removing any dirt or sand with a soft brush so as to avoid scratching the finish. Wipe down the scope with a damp cloth and follow with a dry cloth. Finally, going over the tube with a silicone treated cloth will restore luster and protect the scope against corrosion. Be careful not to touch the any of the lenses with the silicone cloth.

WARRANTY

LIFETIME LIMITED PRODUCT WARRANTY

This product comes with a Lifetime Guarantee against defects in both materials and workmanship. In the event a defect that is covered by the foregoing warranty occurs during the applicable period stated above, ATN, at its option, will either repair or replace the product, and such action on the part of ATN shall be the full extent of ATN's liability, and the Customer's sole and exclusive remedy. This warranty does not cover a product (a) used in other than its normal and customary manner; (b) subjected to misuse, (c) subjected to alterations, modifications or repairs by the Customer or by any party other than ATN without prior written consent of ATN; (d) special order or "close-out" merchandise or merchandise sold "as-is" by either ATN or the ATN dealer; or (e) merchandise that has been discontinued by the manufacturer and either parts or replacement units are not available due to reasons beyond the control of ATN. ATN shall not be responsible for any defects or damage that in ATN's opinion is a result from the mishandling, abuse, misuse, improper storage or improper operation, including use in conjunction with equipment which is electrically or mechanically incompatible with or of inferior quality to the product, as well as failure to maintain the environmental conditions specified by the manufacturer. This warranty is extended only to the original purchaser. Any breach of this warranty shall be waived unless the customer notifies ATN at the address noted below within in the applicable warranty period.

THE CUSTOMER UNDERSTANDS AND AGREES THAT EXCEPT FOR THE FOREGOING WARRANTY, NO OTHER WARRANTIES WRITTEN OR ORAL, STATUTORY, EXPRESSED OR IMPLIED, INCLUDING ANY IMPLIED WARRANTY OF MERCHANTABILITY OR FITNESS FOR A PARTICULAR PURPOSE, SHALL APPLY TO THE PRODUCT. ALL SUCH IMPLIED WARRANTIES ARE HEREBY AND EXPRESSLY DISCLAIMED.

LIMITATION OF LIABILITY

ATN will not be liable for any claims, actions, suits, proceedings, costs, expenses, damages or liabilities arising out of the use of this product. Operation and use of the product are the sole responsibility of the Customer. ATN's sole undertaking is limited to providing the products and services outlined herein in accordance with the terms and conditions

of this Agreement. The provision of products sold and services performed by ATN to the Customer shall not be interpreted, construed regarded, either expressly or implied as being the benefit of or creating any obligation toward any third party of legal entity outside ATN and the Customer: ATN's obligations under this Agreement extend solely to the Customer. ATN'S LIABILITY HEREUNDER FOR DAMAGES. REGARDLESS OF THE FORM OR ACTION, SHALL NOT EXCEED THE FEES OR OTHER CHARGES PAID TO ATN BY THE CUSTOMER OR CUSTOMER'S DEALER. ATN SHALL NOT, IN ANY EVENT, BE LIABLE FOR SPECIAL, INDIRECT, INCIDENTAL OR CONSEQUENTIAL DAMAGES. INCLUDING, BUT NOT LIMITED TO LOST INCOME, LOST REVENUE OR LOST PROFIT WHETHER SUCH DAMAGES WERE FORESEEABLE OR NOT AT THE TIME OF PURCHASE AND WHETHER OR NOT SUCH DAMAGES ARISE OUT OF A BREACH OF WARRANTY, A BREACH OF AGREEMENT, NEGLIGENCE, STRICT LIABILITY OR ANY OTHER THEORY OF LIABILITY.

PRODUCT WARRANTY REGISTRATION

In order to validate the warranty on your product, ATN must receive a completed Product Warranty Registration Card for each unit or complete warranty registration on our website at www.atncorp.com. Please complete the included form and immediately mail it to our Service Center: ATN Corporation, 1341 San Mateo Avenue, South San Francisco, CA 94080.

OBTAINING WARRANTY SERVICE

To obtain warranty service on your unit, please contact our Customer Service department and request an RMA number. Once you have received your RMA # please mark this # on the outside of the shipping box and take or send the product, postage paid, with a copy of your sales receipt to our service center, ATN Corporation at the address noted above. All merchandise must be fully insured with the correct postage; ATN will not be responsible for improper postage or missing or damaged merchandise during shipment. Packages that do not have an RMA # clearly marked on the outside of the package will be delayed in being processed.



For customer service and technical support, please contact
American Technologies Network Corp.

North American Office

1341 San Mateo Avenue, South San Francisco, CA 94080

Toll Free Phone: 800-910-2862

Phone: 650-989-5100; fax: 650-875-0129

European Office

phone: 44(0)870-0111286, fax: 44(0) 845-3349142

The following countries can use our
toll free number 00 800 9102-8620

Austria, France, Germany, Holland, Italy, Spain, Sweden, Switzerland

www.atncorp.com